

order number: J01151R0051

R-SMA Straight Plug G30 (1.5/3.8); G54 (1.5/3.8 FLEX) crimp/crimp

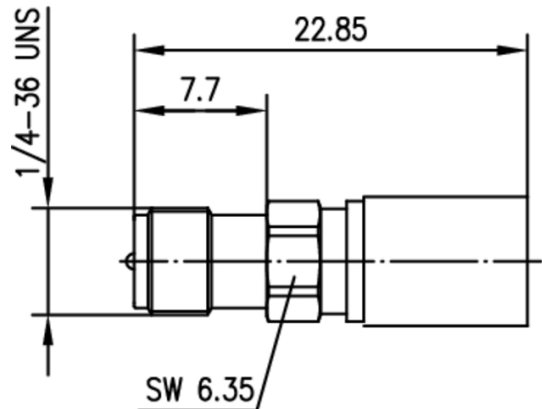

Technical Attributes	
Cable group; cable	G30 (1.5/3.8); G54 (1.5/3.8 FLEX) S 04172 D WCX240  1.4/3.8 AF 7808A CNT-240 H 155 HPF 240 LMR-240 LOW LOSS 1.4/3.8 MRC 240 AFB SPEEDFOAM 240 HFJ TZC 500 25
Remarks	crimp/crimp
Assembly	C2731
Crimp die	N01003A0056
Z	Ω
Dimensions	
MIL-Std.	

### Product description

The term “reverse-polarised connectors” is used where, for example, a standard cable plug has a female centre contact, instead of a male centre contact. Reverse-polarised connectors are mainly used in WLAN applications and are available in three different series: R-SMA connectors are supplied with a threaded coupling, are vibration resistant and can be used up to frequencies of over 6 GHz (depending on type). The impedance is controlled at 50 Ω.

R-TNC connectors are supplied with a threaded coupling, are vibration resistant and can be used up to frequencies of over 6 GHz. The impedance is controlled at 50 Ω.

R-BNC connectors are supplied with a bayonet coupling. Connector designs are available with crimp cable termination. Mating face sealing for series R-SMA and R-TNC between plug and jack (mated) meet IP 68 requirements; series R-BNC meets IP 54 requirements.

Mechanical Characteristics	
Durability (mating cycles)	≥ 500
Recommended coupling torque	R-SMA: 79 - 113 Ncm; R-TNC: 46 - 69 Ncm
Material: spring contacts	R-SMA: CuBe2; R-TNC/R-BNC: CuBe2, CuNi1Pb1P(C97)
Material: solid contact parts	CuZn39Pb3
Material: crimp ferrule	Cu / CuZn39Pb3
Material: serrated lock washer	CuSn6
Material: insulators	PTFE PTFE
Material: gaskets	Silicone Silicone
Material: outer conductor	CuZn39Pb3
Material: other metal parts	CuZn39Pb3
Finish: Inner conductor	R-SMA: Cu1Ni2Au1.27; R-TNC / R-BNC: Cu1Ni2Au0.8
Finish: Outer conductor	R-SMA: NiPAu; R-TNC / R-BNC: Cu2Ni5
Finish: Other metal parts	R-SMA: Cu1Ni2Au0.2; R-TNC / R-BNC: Cu2Ni5

Climatic Characteristics	
Climatic category acc. to IEC 60068 - 1	R-SMA: 55/155/56
Types with PTFE insulator	R-TNC / R-BNC: 40/155/21

Electrical Characteristics	
Impedance	50 Ω
Working voltage	R-SMA: ≤ 335 V/50 Hz; R-TNC / R-BNC: ≤ 500 Veff/50 Hz

---

Contact resistance inner conductor	R-SMA: $\leq 3 \text{ m}\Omega$ ; R-TNC: $\leq 10 \text{ m}\Omega$ ; R-BNC: $\leq 20 \text{ m}\Omega$
Contact resistance outer conductor	R-SMA: $\leq 2 \text{ m}\Omega$ ; R-TNC: $\leq 2.5 \text{ m}\Omega$ ; R-BNC: $\leq 5 \text{ m}\Omega$
Insulation resistance	$\geq 5 \text{ G}\Omega$
Frequency range up to	R-BNC: 4 GHz; R-SMA: 6 GHz; R-TNC: 6 GHz