

# Installation guide for In-Building omni antennas

## 1 Introduction and safety advice

This instruction shall provide information how to install the antenna with mounting kits.

The installation of Thin Omni Chip antennas is not recommended for metal ceilings or nearby any metallic materials. Additional Isolation/Absorbing accessories can be applied for improving the Antenna VSWR value.

Omni antennas must not be rotated after connecting the feeder cables.

All shown tasks are intended to be carried out by qualified personnel only. Safety rules apply (e.g. for working with heavy loads, radio frequency power signals or tools). In order to prevent damage to equipment and humans, make sure that no RF power is present at the combiner during installation.

Please note that satisfactory performance of the system (especially in terms of intermodulation) can only be achieved if all jumper cables and connectors are handled properly. Please make sure that all connectors are clean and free from metal dust or dirt. Avoid sharp bending of the connecting jumper cables.

After carrying out all described steps, the antenna is ready for use. Make sure that the specified environmental conditions for operation are not exceeded.

SPINNER does not guarantee for any faults or damage resulting from improper installation.

## 2 Installation

### 2.1 Install the antenna

#### Method 1: Through hole mounting

Step 1: Drill a hole with  $\geq 22$  mm resp.  $\geq 28$  mm diameter into suspended ceiling.

- **22 mm** hole diameter is applicable for antennas A77137, A77137C0001, A77141, A77142, A77142C0001, A77143, A77144, A77145, A77146, A77146C0003 and A77148.
- **28 mm** hole diameter is applicable for antennas A77147, A77670 and A77684.



Step 2: Pass the antenna connectors through the hole.

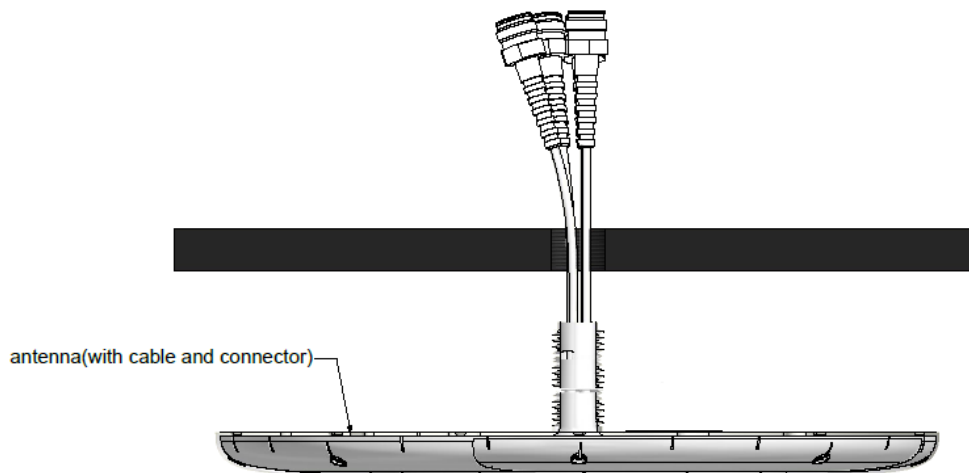

Step 3: Secure the antenna with supplied plastic lock nut.

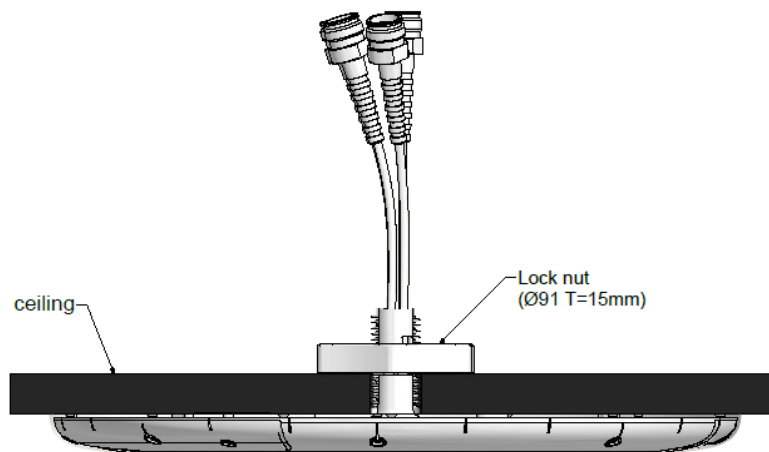

## Method 2: Tightening screw mounting

Drill a hole with  $\geq 22$  mm diameter into the suspended ceiling to pass the connectors of the antenna. Then drill 2 resp. 4 holes with 6 mm diameter into suspended ceiling and put the plastic dowels into the holes. Lock the antenna with tightening screws (M4\*25 mm), then cover lids.

The method is applicable for antennas A77137, A77137C0001, A77142, A77142C0001, A77143, A77146, A77146C0003, A77147 and A77148.

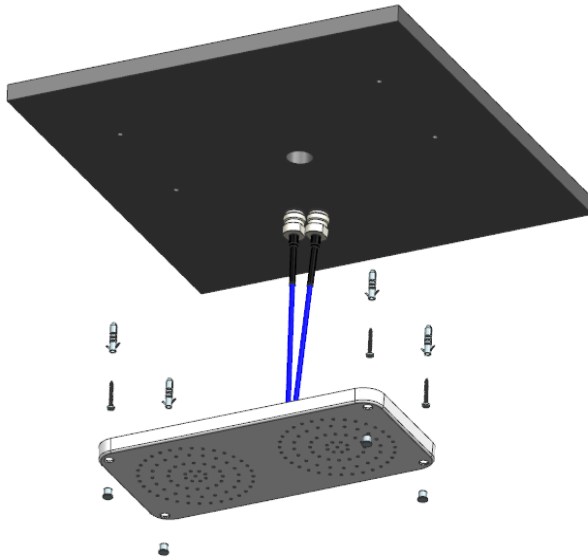

### 2.2 Warning:

Please respect the cable bending radius of minimum 40 mm.

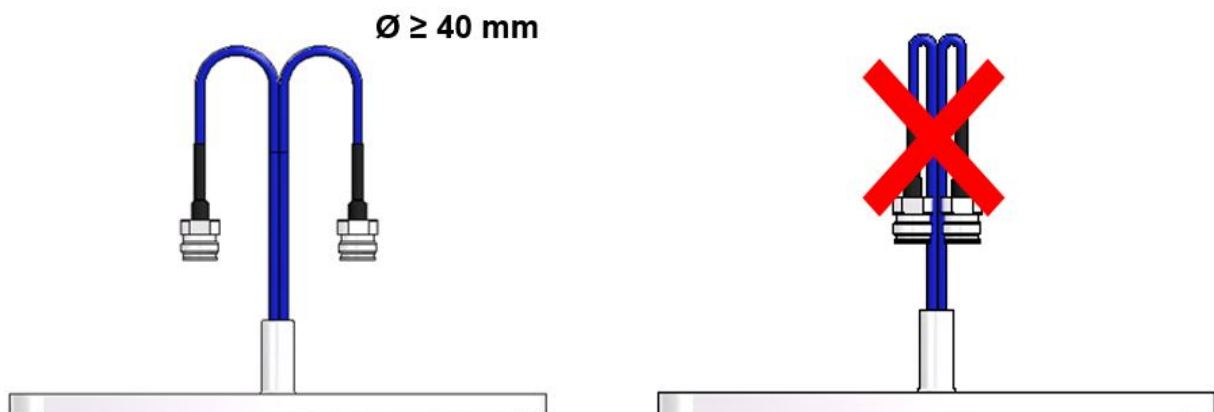

### 2.3 Install the Interference Absorber

Interference absorbers are not available for antennas A77148, A77670 and A77684.

Step 1: Drill a hole with  $\geq 29$  mm diameter and three holes with 6 mm diameter in the ceiling using the provided drilling jig.

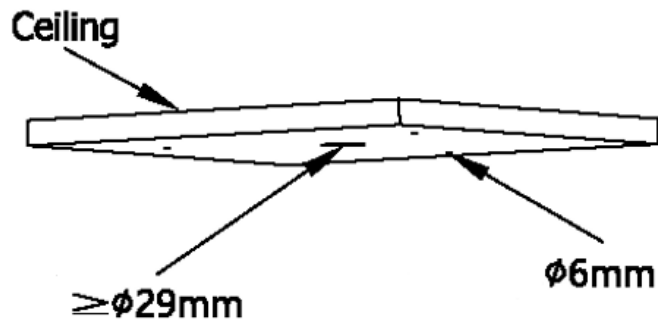

Step 2: Fix the Interference Absorber to the ceiling with three plastic dowels and M4\*25 screws.

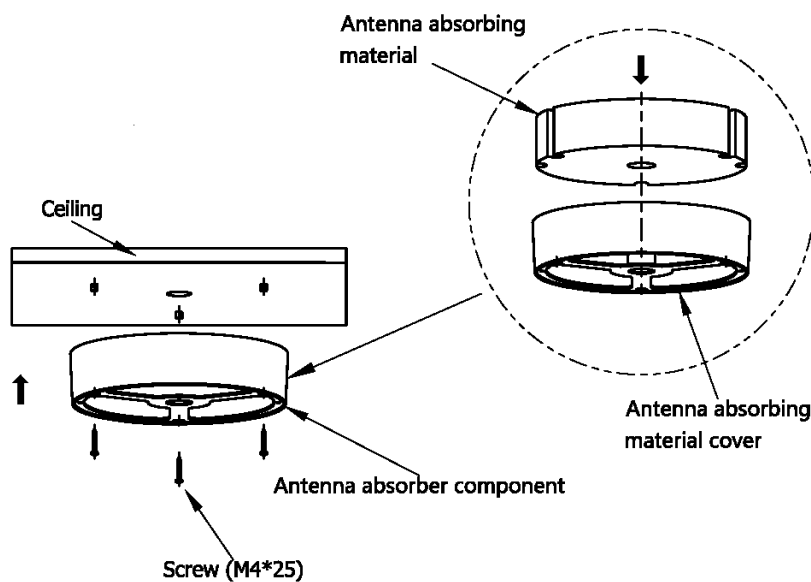

Step 3: Secure the antenna to the Interference Absorber with two M4\*25 screws.

