

NO	DESCRIPTION	MATERIAL	Q'TY	FINISH	REMARK
1	SHELL	BRASS	1	NICKEL	B-SMA0043-N
2	GASKET	RUBBER	1	RUBBER	RU-0008
3	WASHER	BRASS	1	NICKEL	W-0012
4	INSULATION	TEFLON	1	TEFLON	I-0126T
5	BODY 1	BRASS	1	NICKEL	B-SMA0154-N
6	BODY 2	BRASS	1	NICKEL	B-BNC0401-N
7	PIN	BRASS	1	GOLD	P-SMA0257-G
8	INSULATION	TEFLON	1	TEFLON	I-0189T
9	WASHER	BRASS	1	NICKEL	W-0007-N

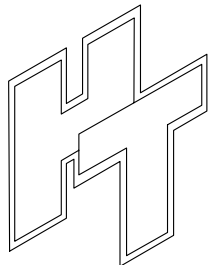
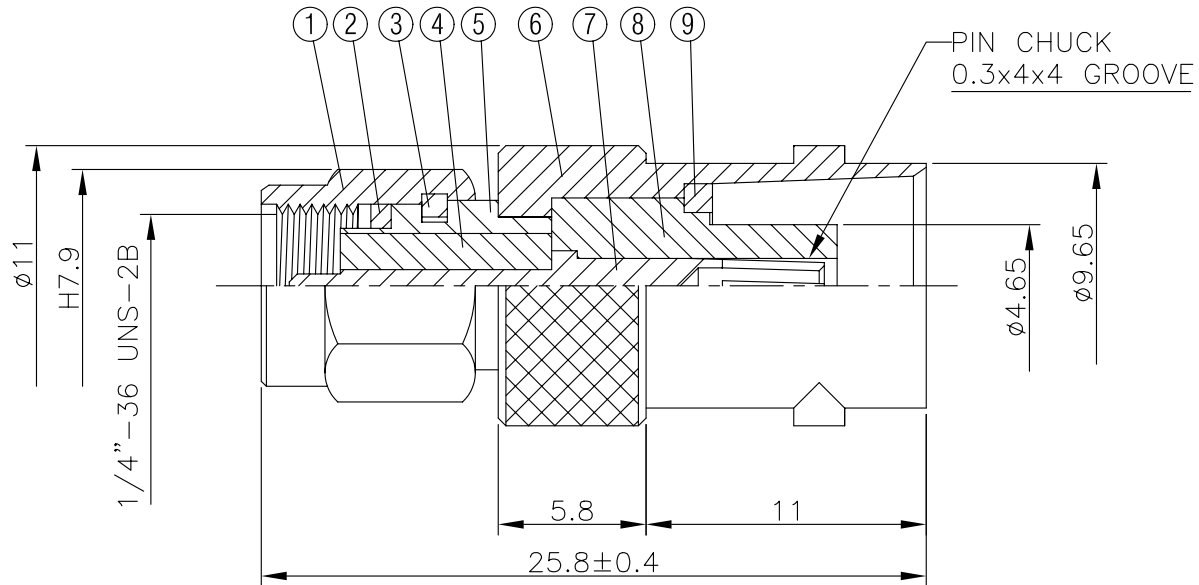
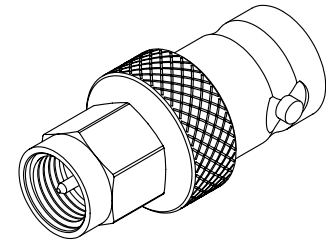

HUS-TSAN GROUP CO., LTD.
P.O. BOX 40-76 TAINAN TAIWAN, R.O.C.

TITLE
SMA MALE - BNC FEMALE ADAPTOR

PART NO. SMA-20-TGN

DRAWING NO. SMA 20 TGN

DRAWN	MARY	DATE	96.03.29
CHECKED	蘇姿潔	DATE	
Q.A.	馮健華	DATE	
APPROVAL	徐燦霖	DATE	
REVISION		DATE	

DIMENSIONS ARE IN MILLIMETERS

UNLESS OTHERWISE SPECIFIED
TOLERANCE

0.5-5 = ±0.2	120-315 = ±1
5-30 = ±0.4	315-1000 = ±1.6
30-120 = ±0.6	1000-2000 = ±2.4

SCALE 4:1 SIZE A

REVISION

DESCRIPTION	ENGINEER