



Cable hanger for HELIFLEX® Air-dielectric coaxial cable

Hangers for the installation of HELIFLEX® cables on different supporting profiles.
Cable Clamp and Extended Counterbed hot-galvanized steel
Screw: stainless steel.



picture shows the 1L4 version for illustration purpose only

Technical Features

GENERAL SPECIFICATIONS

Product Line		Coaxial Cable Accessories
Product Type		Hanger
Hanger Type		Angle iron 40mm (1.575")
Transmission Line Type		HCA495
Cable Type		Air Dielectric

MECHANICAL SPECIFICATIONS

Cable Size		5"
Material		Cable Clamp : hot-dip galvanized Extended Counterbed : hot-dip galvanized Screw: Stainless steel
Recommended / Maximum Clamp Spacing	m (ft)	1 / 2 (3.3 / 6.6)

TEMPERATURE SPECIFICATIONS

Operation Temperature	°C (°F)	-50 to 85 (-58 to 185)
Storage Temperature	°C (°F)	-50 to 85 (-58 to 185)

PACKAGING INFORMATION

Package Quantity		1
------------------	--	---

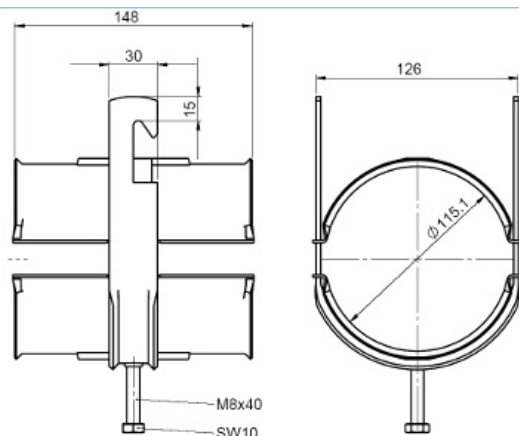

2200255-b_HCH-495-1L4_2 (2).png

HCH Clamps available for different types of interfaces:

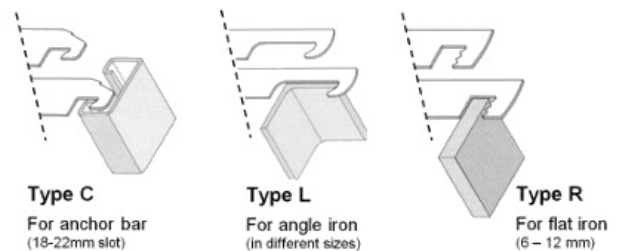

HCH Clamps available for different types of Interfaces.png

External Document Links

Notes

Hangers for angle iron 40mm (1.575")