

NO	DESCRIPTION	MATERIAL	Q'TY	FINISH	REMARK
1	BODY 1	BRASS	1	NICKEL	B-SMA0065-N
2	INSULATION 1	TEFLON	1	TEFLON	I-0160T
3	BODY2	BRASS	1	NICKEL	B-BNC0361-N
4	WASHER	BRASS	1	BRASS	W-0025-N
5	SPRING	SK-5	1	NICKEL	W-0027-N
6	WASHER	BRASS	1	NICKEL	W-0026-N
7	GASKET	SI RUBBER	1	RUBBER	RU-0010
8	BODY 3	BRASS	1	NICKEL	B-BNC0184-N
9	INSULATION 2	TEFLON	1	TEFLON	I-0172T
10	PIN	PH.BRONZE	1	GOLD	P-SMA0274-G

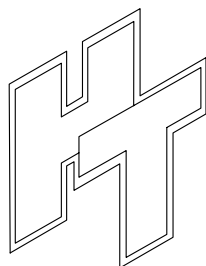
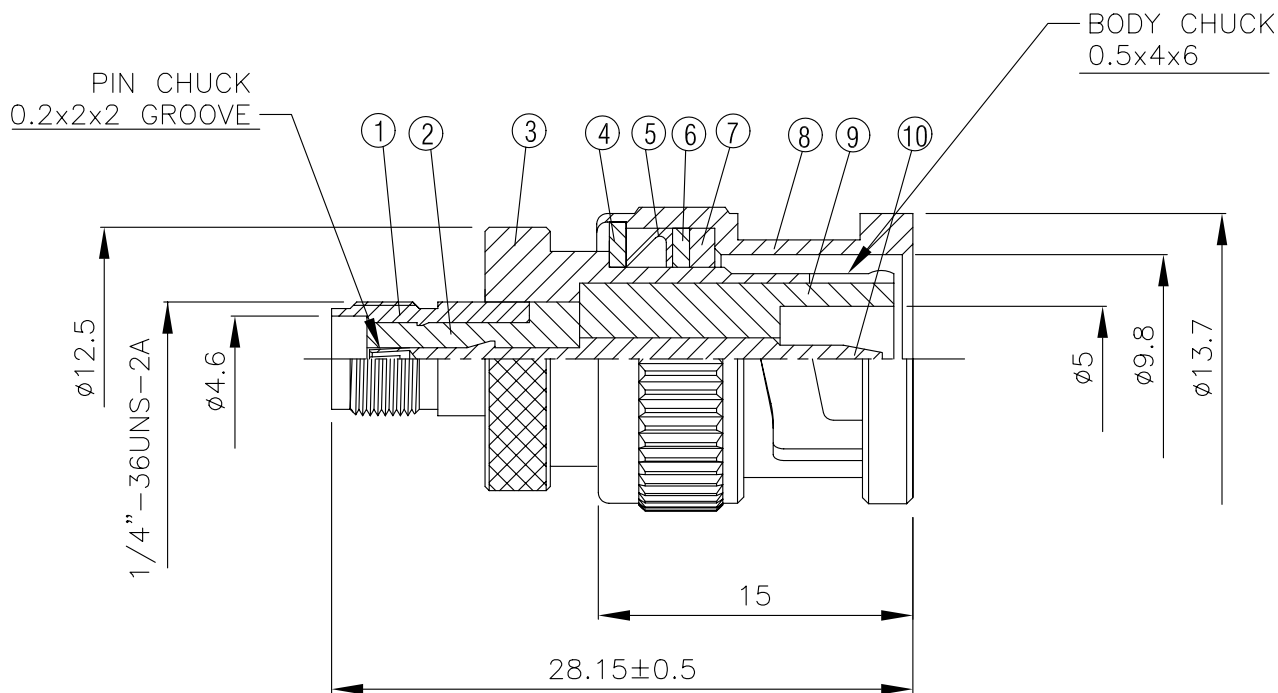
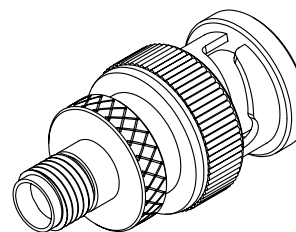

HUS-TSAN GROUP CO., LTD.

P.O. BOX 40-76. TAINAN, TAIWAN, R.O.C.

TITLE
SMA FEMALE-BNC MALE ADAPTOR

PART NO. SMA-25-TGN

DRAWING NO. SMA 25 TGN

DRAWN MARY DATE 96.03.27

CHECKED 蘇姿潔 DATE

Q.A. 馮健華 DATE

APPROVAL 徐燦霖 DATE

REVISION DATE

DIMENSIONS ARE IN MILLIMETERS

UNLESS OTHERWISE SPECIFIED
TOLERANCE

0.5-5=±0.2 120-315=±1

5-30=±0.4 315-1000=±1.6

30-120±0.6 1000-2000=±2.4

SCALE 4:1 SIZE A

REVISION

DESCRIPTION ENGINEER