

HC872

HC872 Dual-Band Helical Antenna + L-Band

Frequency Coverage: GNSS/QZSS-L1/L2, GLONASS-G1/G2, Galileo-E1, BeiDou-B1 + L-Band correction services

The patented HC872 helical antenna is designed for precision positioning, covering the GPS/QZSS-L1/L2, GLONASS-G1/G2, Galileo-E1, and BeiDou-B1 frequency bands, including the satellite-based augmentation system (SBAS) available in the region of operation [WAAS (North America), EGNOS (Europe), MSAS (Japan), or GAGAN (India)], as well as and L-Band correction services.

Weighing only 42 g, the light and compact HC872 features a precision-tuned helix element that provides excellent axial ratios and operates without the requirement of a ground plane, making it ideal for a wide variety of applications, including unmanned aerial vehicles (UAVs).

The HC872 features an industry-leading low current, low-noise amplifier (LNA) that includes an integrated low-loss pre-filter to prevent harmonic interference from high-amplitude signals, such as 700 MHz band LTE and other nearby in-Band cellular signals.

All Tallysman housed helical antenna elements are protected by a robust military-grade IP67-compliant plastic enclosure. The enclosure's base provides two threaded inserts for secure attachment, as well as a rubber O-ring around the outer edge to seal the antenna base and its integrated male SMA connector.

Tallysman's helical family has passed a rigorous 30-hour vibration test procedure, consisting of five cycles of 2-hour tests per axis (x, y, z):

- Cycle 1: 1.05 Grms;
- Cycle 2: 1.20 Grms;
- Cycle 3: 1.35 Grms;
- Cycle 4: 3.67 Grms;
- Cycle 5: 3.67 Grms.

For mounting instructions, visit:

https://www.tallysman.com/downloads/Helical_Mounting_Instruction.pdf



Applications

- Autonomous unmanned aerial vehicles (UAVs)
- Precision GNSS positioning
- Precision land survey positioning
- Mission-critical GNSS timing
- Network timing and synchronization
- Sea and land container tracking
- Fleet management and asset tracking
- Marine and avionics systems
- Law enforcement and public safety

Features

- Very low noise preamp (2.0 dB typ.)
- Axial ratio (≤ 0.5 dB at zenith)
- LNA gain (28 dB typ. | 35 dB typ.)
- Low current (12 mA typ. | 18 mA typ.)
- ESD circuit protection (15 kV)
- Invariant performance from 2.2 to 16 VDC
- IP67, REACH, and RoHS compliant

Benefits

- Extremely light (42 g)
- Ideal for RTK and PPP surveying systems
- Excellent RH circular polarized signal reception
- Great multipath rejection
- Increased system accuracy
- Excellent signal-to-noise ratio
- Industrial temperature range
- Rugged design, ideal for harsh environments

About Tallysman: With global headquarters and manufacturing in Ottawa, Canada, Tallysman is a leading manufacturer of high-precision antennas and components for Global Navigation Satellite System (GNSS) applications. Tallysman's mission is to support the needs of a new generation of positioning systems by delivering unprecedented antenna precision at competitive prices. Learn more at www.tallysman.com

Revision: 1.0

Contact us:
info@tallysman.com
T: +1 613 591-3131

HC872 Dual-Band Helical Antenna + L-Band

Frequency Coverage: GNSS/QZSS-L1/L2, GLONASS-G1/G2, Galileo-E1, BeiDou-B1 + L-Band correction services

Antenna

Technology: Dual-frequency, RHCP quadrifilar helix

		Gain	Axial Ratio
		dBic typ. at Zenith	dB at Zenith
GNSS			
GPS / QZSS	L1	2.5	≤ 0.5
	L2	2.8	≤ 0.5
	L5	-	-
GLONASS	G1	1.8	≤ 0.5
	G2	1.9	≤ 0.5
	G3	-	-
Galileo	E1	2.5	≤ 0.5
	E5a	-	-
	E5b	-	-
	E6	-	-
BeiDou	B1	2.5	≤ 0.5
	B2	-	-
	B2a	-	-
	B3	-	-
IRNSS / NavIC	L5	-	-
QZSS	L6	-	-
L-band correction services		2.2	≤ 0.5
Satellite Communications			
Iridium		-	-
Globalstar		-	-
Phase Centre			
Phase Centre Variation (PCV)		± 3.0 mm (all freq.)	
Phase Centre Offset (PCO)		32 mm @ L1 37 mm @ L2	

Mechanicals

Mechanical Size	44.2 mm (dia.) x 62.4 mm (h.)
Weight	42 g
Available Connectors	SMA (male)
Radome / Enclosure	Radome and Base: EXL9330
Mount	3x M2.5 screws

Environmental

Operating Temperature	-45 °C to +85 °C
Storage Temperature	-55 °C to +95 °C
Random Vibration	MIL-STD-810E - Test method 514.5 4 hours per axis (x, y, z) at 3.674 Grms
Shock and Drop	-
Salt Fog	-
IP Rating (housing)	IP67
Compliance	IPC-A-610, FCC, RED / CE Mark, RoHS, REACH

Warranty:

Parts and Labour	3-year standard warranty
------------------	--------------------------

Low Noise Amplifier (LNA) - Measured at 3.0 VDC and 25°C

Frequency Bandwidth	Out-of-Band Rejection
Lower Band	1217 - 1255 MHz > 35 dB @ < 1100 MHz > 47 dB @ < 1190 MHz > 48 dB @ < 1350 MHz
L-band corrections services	1539 - 1559 MHz
Upper Band	1559 - 1606 MHz > 36 dB @ < 1400 MHz > 32 dB @ < 1450 MHz > 45 dB @ > 1700 MHz

Architecture	Pre-filter → LNA
Gain	28 dB typ. 35 dB typ.
Noise Figure	2.0 dB typ.
VSWR	< 1.5:1 typ. 1.8:1 max.
Supply Voltage Range	2.2 to 12 VDC
Supply Current	12 mA typ. (28 dB gain) 18 mA typ. (35 dB gain)
ESD Circuit Protection	15 kV air discharge
P 1dB Output	-
Group Delay Variation	-

Installation Instructions

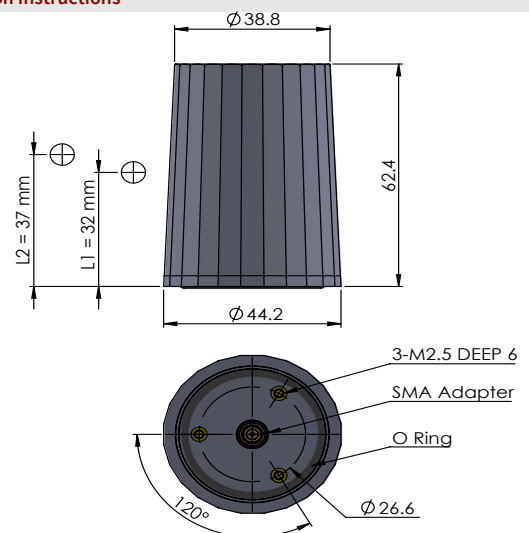

Ordering Information

Part Number: **33-HC872-xx**

where xx = gain (28 or 35 dB)

Please refer to our **Ordering Guide** to review available radomes and connectors at: <https://www.tallysman.com/resource/tallysman-ordering-guide/>