

| NO | DESCRIPTION | MATERIAL | Q'TY | FINISH | REMARK |
|----|--------------|-----------|------|--------|-----------|
| 1 | BODY 1 | BRASS | 1 | NICKEL | B-N1123-N |
| 2 | INSULATION | TEFLON | 1 | TEFLON | I-0124T |
| 3 | PIN | BRASS | 1 | GOLD | P-N0788-G |
| 4 | INSULATION 2 | TEFLON | 1 | TEFLON | I-0151T |
| 5 | GASKET | SI RUBBER | 1 | RUBBER | RU-0009 |
| 6 | WASHER | BRASS | 1 | NICKEL | W-0005-N |
| 7 | NUT | BRASS | 1 | NICKEL | N-0007-N |
| 8 | BODY 2 | BRASS | 1 | NICKEL | B-N0320-N |

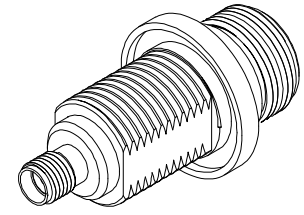

D
C
B
A

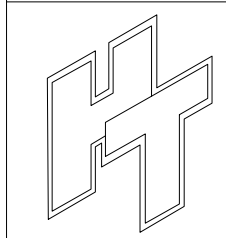
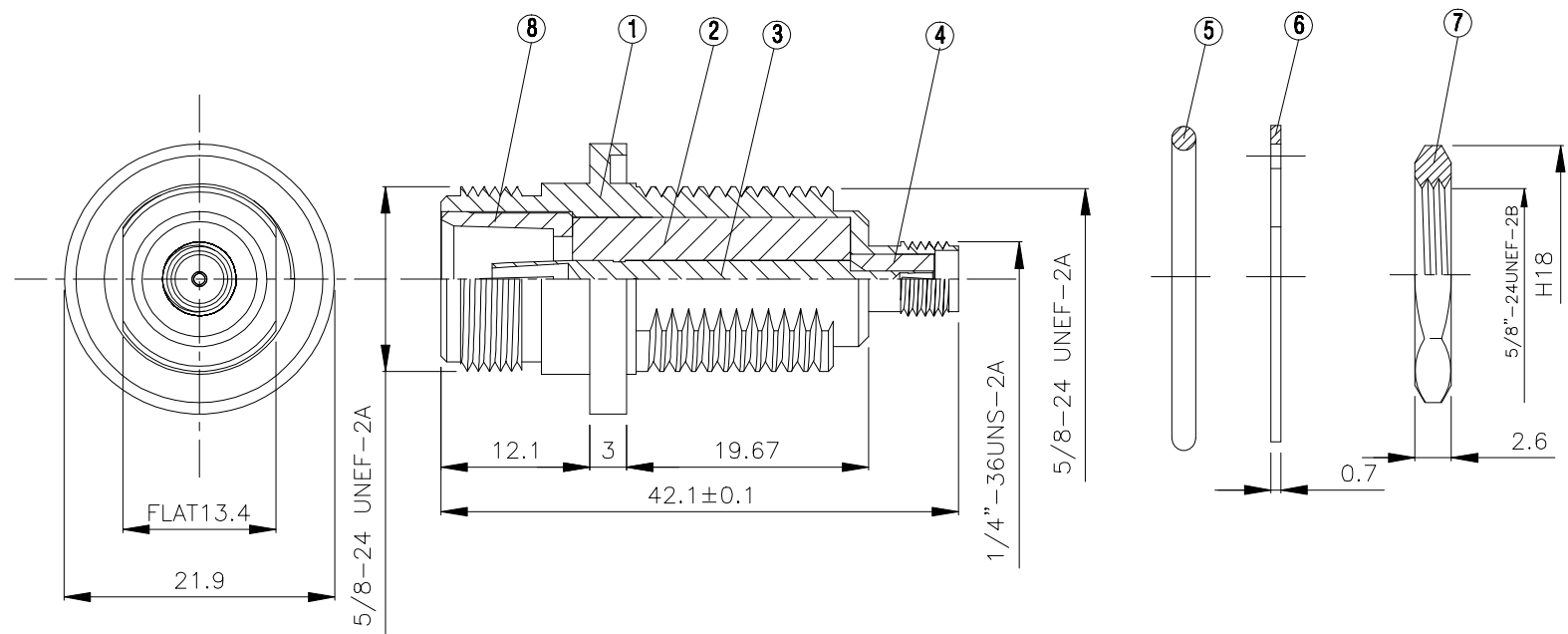

HUS-TSAN GROUP CO., LTD.
 P.O. BOX 40-76. TAINAN. TAIWAN, R.O.C.
 TITLE: N JACK - SMA JACK ADAPTOR
 PART NO. N-48-TGN
 DRAWING NO. N 48 TGN

| | | | |
|----------|------|------|----------|
| DRAWN | MARY | DATE | 96.06.18 |
| CHECKED | 蘇志欣 | DATE | |
| Q.A. | 蘇姿潔 | DATE | |
| APPROVAL | 徐燦霖 | DATE | |
| REVISION | | DATE | |

| | | | |
|--------------------------------------|------|-----------|------|
| DIMENSIONS ARE IN MILLIMETERS | | | |
| UNLESS OTHERWISE SPECIFIED TOLERANCE | | | |
| 0.5-5 | ±0.2 | 120-315 | ±1 |
| 5-30 | ±0.4 | 315-1000 | ±1.6 |
| 30-120 | ±0.6 | 1000-2000 | ±2.4 |
| SCALE | 4:1 | SIZE | A |

| | |
|-------------|----------|
| REVISION | |
| DESCRIPTION | ENGINEER |
| | |
| | |

4 3 2 1