

NO	DESCRIPTION	MATERIAL	Q'TY	FINISH	REMARK
1	NUT	BRASS	1	NICKEL	
2	BODY 1	BRASS	1	NICKEL	B-N1270-N
3	INSULATION	TEFLON	1	TEFLON	I-0448T
4	INSULATION	TEFLON	1	TEFLON	I-0117T
5	BODY 2	BRASS	1	NICKEL	B-N0320-N
6	PIN	BRASS	1	GOLD	P-N0837-G
7	BODY 3	BRASS	1	GOLD	
8	WASHER	BRASS	1	NICKEL	W-0005-N
9	NUT	BRASS	1	NICKEL	N-0007-N
10	GASKET	RUBBER	1	RUBBER	RU-0009

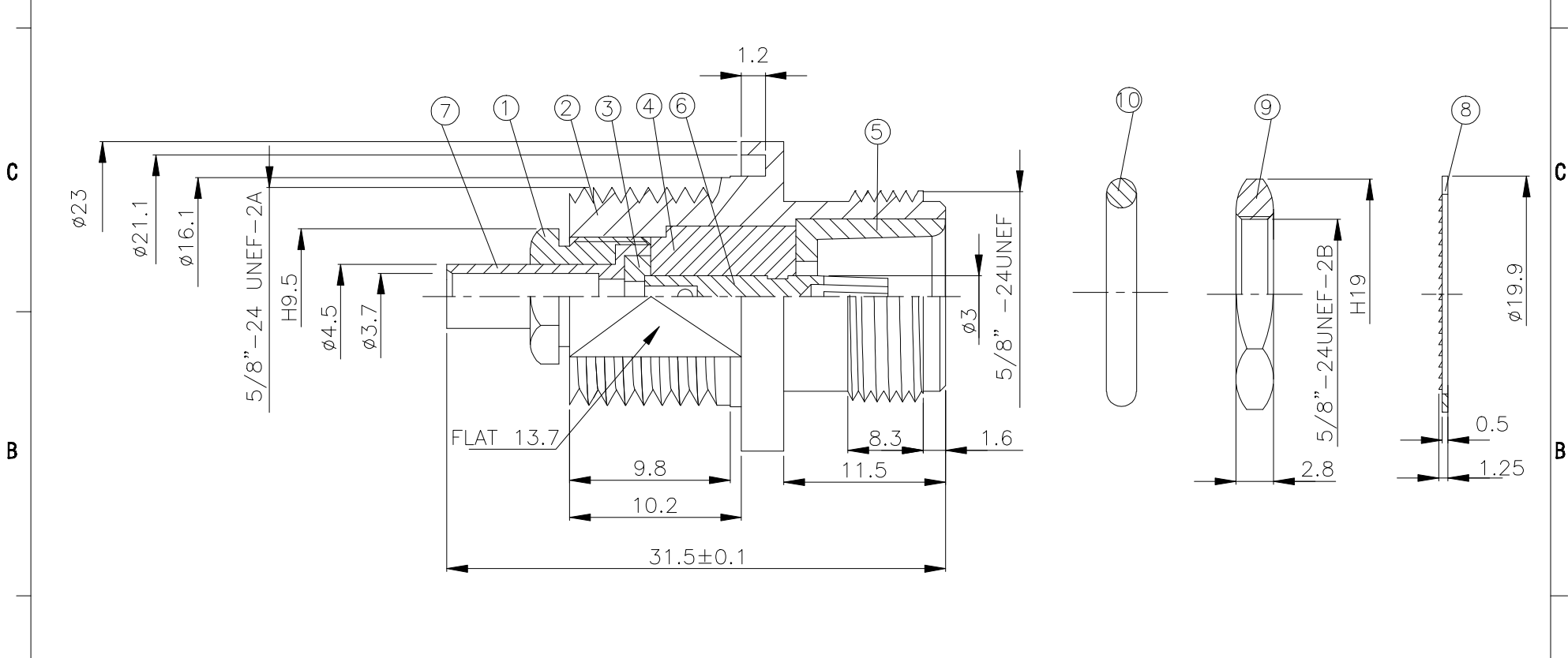
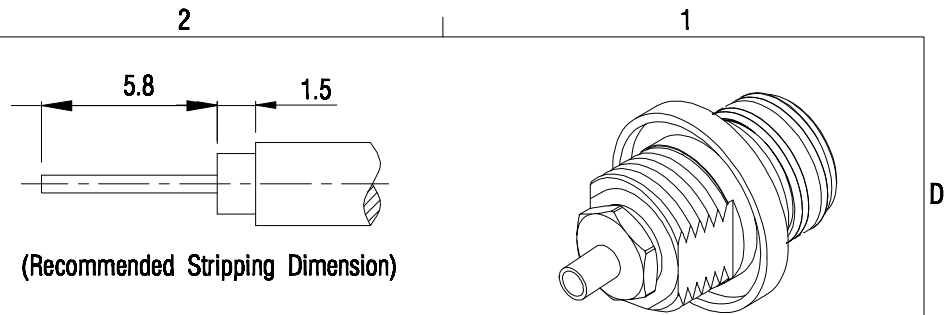

	<b>HUS-TSAN GROUP CO., LTD</b> P.O. BOX 40-76.TAINAN TAIWAN,R.O.C.		DRAWN <b>林孟翰</b> DATE 104.02.25	DIMENSIONS ARE IN MILLIMETERS		REVISION	
	<b>TITLE N BULKHADE FEMALE SOLDER FOR RG-402/U</b>		CHECKED <b>林孟翰</b> DATE 104.02.25	UNLESS OTHERWISE SPECIFIED TOLERANCES		DESCRIPTION	ENGINEER
	PART NO. <b>N-45V2-TGN</b>		Q.A. <b>莊千慧</b> DATE	0.5-5=±0.2    120-315=±1			
	DRAWING NO. <b>N-45V2-TGN</b>		APPROVAL <b>徐燦霖</b> DATE	5-30=±0.4    315-1000=±1.6			
			REVISION DATE	30-120=±0.6    1000-2000=±2.4	SCALE 4:1	SIZE A	