

NO	DESCRIPTION	MATERIAL	QTY	FINISH	REMARK
1	BODY 1	BRASS	1	GOLD	B-SMA0632-G
2	INSULATION 1	TEFLON	1	TEFLON	I-0286T
3	PIN	BE CU	1	GOLD	P-SMB0420-G
4	INSULATION 2	TEFLON	1	TEFLON	I-0053T
5	BODY 2	BRASS	1	GOLD	B-SMB0263-G
6	BODY 3	BRASS	1 <td GOLD	B-SMB0245-G	
7	WASHER	BE CU	1	GOLD	W-0035-G

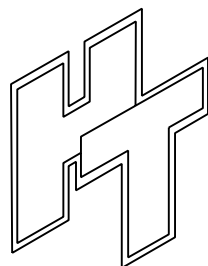
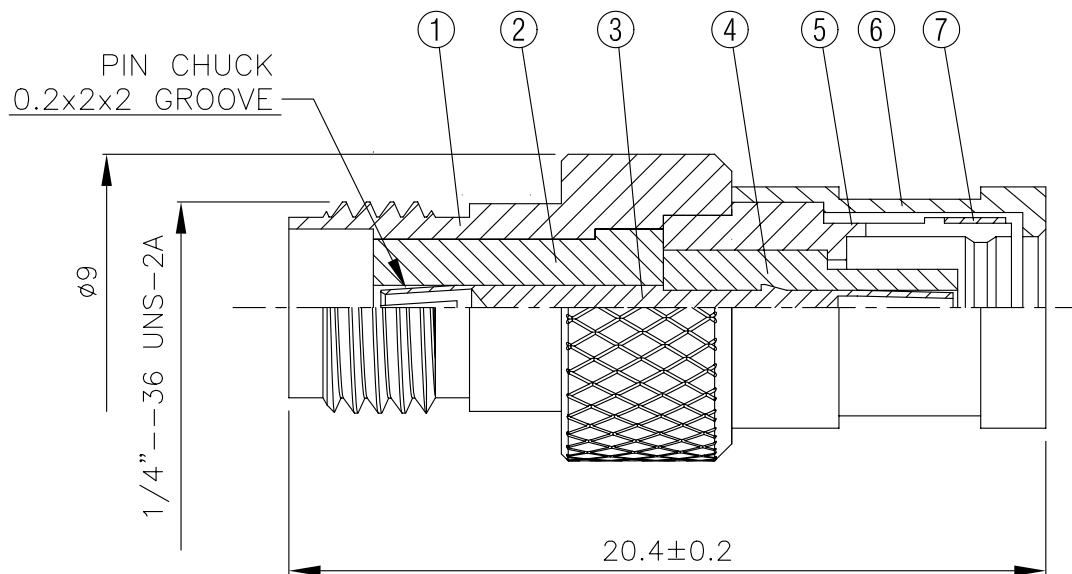
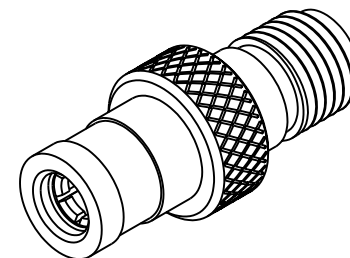

HUS-TSAN GROUP CO., LTD.

P.O. BOX 40-76. TAINAN, TAIWAN, R.O.C.

TITLE SMA FEMALE - SMB FEMALE ADAPTOR

PART NO. SMA-73-TGG

DRAWING NO. SMA 73 TGG

DRAWN MARY

DATE 96.03.27

CHECKED 黃巧君

DATE

Q.A. 蘇姿潔

DATE

APPROVAL 徐燦霖

DATE

REVISION

DATE

DIMENSIONS ARE IN MILLIMETERS

UNLESS OTHERWISE SPECIFIED TOLERANCE

0.5-5=±0.2	120-315=±1
5-30=±0.4	315-1000=±1.6
30-120±0.6	1000-2000=±2.4

SCALE 4:1 SIZE A

REVISION

DESCRIPTION	ENGINEER