

NO	DESCRIPTION	MATERIAL	Q'TY	FINISH	REMARK
1	BODY 1	BRASS	1	NICKEL	B-TRB0767-N
2	BODY 2	BRASS	1	NICKEL	B-TRB0768-N
3	GASKET	SI RUBBER	1	RUBBER	RU-0001
4	WASHER 1	BRASS	1	NICKEL	W-0026-N
5	WASHER 2	BRASS	1	NICKEL	W-0027-N
6	WASHER 3	BRASS	1	NICKEL	W-0025-N
7	INSULATION 1	TEFLON	1	TEFLON	I-0370T
8	PIN	PH.BRONZE	1	GOLD	P-TRB0537-G
9	INSULATION 2	TEFLON	1	TEFLON	I-0371T
10	PIN 2	BE CU	1	GOLD	P-TRB0536-G
11	INSULATION 3	TEFLON	1	TEFLON	I-0321T
12	INSULATION 4	TEFLON	1	TEFLON	I-0322T
13	BODY 2	BRASS	1	NICKEL	B-TRB0669-N
14	BODY 3	BRASS	1	NICKEL	B-TRB0670-N
15	NUT	BRASS	1	NICKEL	N-0032-N

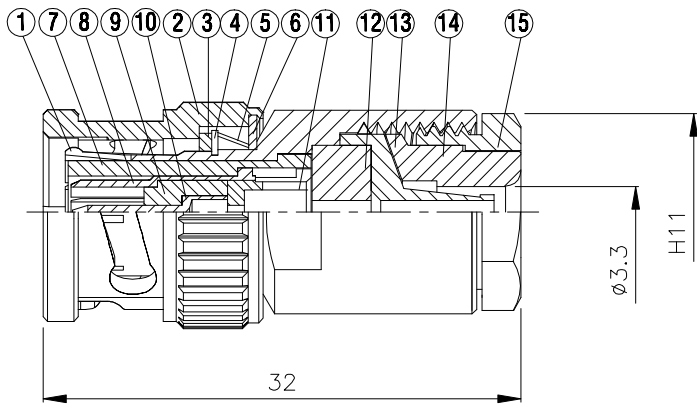
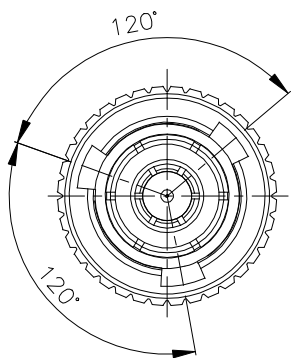
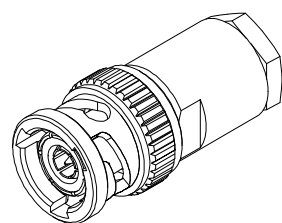
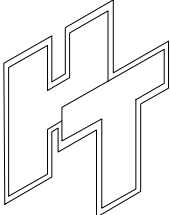

	HUS-TSAN GROUP CO., LTD.		DRAWN	MARY	DATE	93.08.19	DIMENSIONS ARE IN MILLIMETERS		REVISION	
	P.O.BOX 40-76.TAINAN.TAIWAN,R.O.C.		CHECKED	蘇姿潔	DATE		UNLESS OTHERWISE SPECIFIED TOLERANCE		DESCRIPTION	ENGINEER
	TITLE TRB MALE CRIMP FOR .250 DIA TWINAX CABLE		Q.A.	馮健華	DATE		0.5-5=±0.2	120-315=±1		
	PART NO. TRB-02Y-TGN		APPROVAL	徐燦霖	DATE		5-30=±0.4	315-1000=±1.6		
	DRAWING NO. TRB 02Y TGN		REVISION		DATE		30-120±0.6	1000-2000=±2.4		
						SCALE	4:1	SIZE	A	