

AC4990EXF-114



Embedded Multi-Constellation Full-Band Precision GNSS Antenna

Frequency Coverage: GPS L1, L2, L5 | QZSS L6 | GALILEO E1, E5a, E5b, E6 | BEIDOU B1, B2a, B2b, B3 | GLONASS G1, G2, G3 | NavIC L5 + L-Band

The AC4990EXF-114 is a precision-tuned multi-constellation, full-band Accutenna® 4 technology antenna. Supported constellations and signals are, GPS/QZSS-L1/L2/L5 QZSS-L6, GLONASS-G1/G2/G3, Galileo-E1/E5a/E5b/E6, BeiDou-B1/B2/B2a/B3, NavIC-L5, including the satellite-based augmentation system (SBAS) available in the region of operation [WAAS (North America), EGNOS (Europe), MSAS (Japan), or GAGAN (India)], plus L-band Corrections.

The AC4990EXF-114 features a precision-tuned, twin circular quad-feed, stacked patch element, with a 114 mm diameter ground plane PCB. The signals from the four orthogonal feeds are combined through a feed network, amplified in a wideband LNA, then band-split for narrow filtering in each band and further amplified prior to recombination at the output. The AC4990EXF-114 quad-feed Accutenna® 4 technology enables an excellent axial ratio (strongly mitigating multipath) and a tightly grouped phase centre variation (≤ 2 mm from zenith to 15° above horizon). It is ideal for surveying, autonomous vehicle tracking and guidance, precision agriculture, and other applications where precision matters.

The radio frequency spectrum has become more congested as new LTE bands are activated and their signals or harmonic frequencies [e.g. $800\text{MHz} \times 2 = 1600\text{MHz}$ (GLONASS-G1)] can affect GNSS antennas and receivers. In North America, planned Ligado signals at 1525 – 1536 MHz can especially impact GNSS antennas that support space-based L-band Corrections (1539 – 1559 MHz). New LTE signals in Europe [Band 32 (1452 – 1496 MHz)] and Japan [Bands 11 and 21 (1476 – 1511 MHz)] have also been observed to interfere with GNSS signals. In addition, Inmarsat satellite communication (uplink: 1626.5 – 1660.5 MHz) can also affect GNSS signals. The new Calian XF antennas have been designed to mitigate out-of-band signals and prevent GNSS antenna saturation. Calian's custom XF filtering mitigates all existing signals and new Ligado and LTE signals, enabling the antennas and attached GNSS receivers to perform optimally.

The embedded AC4990EXF-114 features eight screw holes to allow for secure mounting and integration. Calian provides support for installation and integration of embedded antennas to enable the integrator to achieve a successful installation and obtain optimum antenna performance.

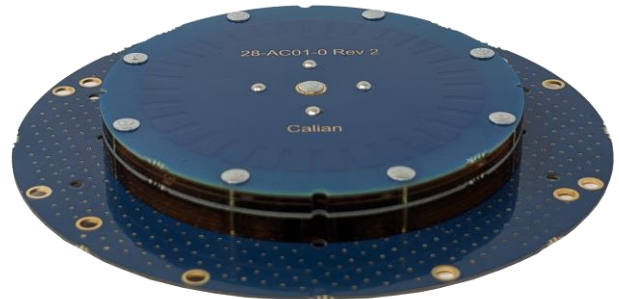

Applications

- High-precision GNSS systems
- Marine navigation
- All precision applications, such as:
 - Autonomous vehicle nav. (land, sea, air)
 - Precision agriculture
 - Land survey rover
 - RTK/PPP systems

Features

- Very low noise preamp (2.5 dB typ.)
- Low axial ratio (< 1.0 dB typ.)
- Tight phase centre variation (≤ 2 mm)
- High-gain LNA (30 dB typ.)
- Low current (17 mA typ.)
- ESD circuit protection (15 kV)
- Invariant performance from 2.5 to 16 VDC

Benefits

- Ideal for full-band RTK surveying systems
- Excellent interference mitigation
- Excellent multipath rejection
- Increased system accuracy
- Excellent signal-to-noise ratio
- CE RED, RoHS, and REACH compliant

About Calian: With global headquarters and manufacturing in Ottawa, Canada, Calian is a leading manufacturer of high-precision antennas and components for Global Navigation Satellite System (GNSS) applications. Calian's mission is to support the needs of a new generation of positioning systems by delivering unprecedented antenna precision at competitive prices. Learn more at www.calian.com/gnss

Revision: 202510

Contact us:
info.gnss@calian.com
T: +1 613 591-3131

Embedded Multi-Constellation Full-Band Precision GNSS Antenna

Frequency Coverage: GPS L1, L2, L5 | QZSS L6 | GALILEO E1, E5a, E5b, E6 | BEIDOU B1, B2a, B2b, B3 | GLONASS G1, G2, G3 | NavIC L5 + L-Band

Antenna

Technology Quad-feed RHCP stacked patch

		Gain	Axial Ratio
		dBic typ. at Zenith	dB at Zenith
GNSS			
GPS / QZSS	L1	4.9	< 1
	L2	4.5	< 1
	L5	2.7	< 1
GLONASS	G1	5.0	< 1
	G2	4.8	< 1
	G3	3.7	< 1
Galileo	E1	4.9	< 1
	E5A	2.7	< 1
	E5B	3.7	< 1
	E6	2.7	< 1
BeiDou	B1	4.9	< 1
	B2b	3.7	< 1
	B2a	2.7	< 1
	B3	4.6	< 1
IRNSS / NavIC	L5	2.7	< 1
QZSS	L6	2.7	< 1
L-Band Services (1539 MHz - 1559 MHz)		4.5	< 1
Satellite Communications			
Iridium		-	-
Globalstar		-	-
Other			
Axial Ratio at 10°	-	Efficiency	-
PCV $\Phi > 15^\circ$	≤ 2 mm	PCO	-

Mechanicals

Size	114 mm (dia.) x 13.2 (h.)
Weight	90 g
Radome	-
Mount	8 Screws 45° apart
Available Connectors	MCX Female

Environmental

Operating Temperature	-40 °C to +85 °C
Storage Temperature	-55 °C to +95 °C
Vibration	MIL-STD-810-E - Test Method 514.5
Shock	MIL-STD-810-G - Test Method 516.6
Salt Fog	-
Other Tests	-
IP Rating	-
Compliance	IPC-A-610, FCC, CE RED, RoHS, REACH

Warranty

Parts and Labour	1-year standard warranty
------------------	--------------------------

Low Noise Amplifier (LNA) - Measured at 3V and 25°C

Frequency Bandwidth	Out of Band Rejection
Lower Band	1164 - 1300 MHz
	≥ 80 dB @ ≤ 1000 MHz ≥ 65 dB @ ≥ 1100 MHz ≥ 30 dB @ ≤ 1125 MHz ≥ 45 dB @ ≥ 1350 MHz
L-Band Corr.	1539 - 1559 MHz
Upper Band	1559 - 1606 MHz
	≥ 30 dB @ ≤ 1500 MHz ≥ 20 dB @ ≤ 1525 MHz ≥ 15 dB @ ≥ 1626 MHz ≥ 60 dB @ ≥ 1650 MHz

Architecture	eXtended Filtering
Gain	28 dB min., 30 dB typ.
Noise Figure	2.5 dB typ.
VSWR	< 1.5:1 typ., 2:1 max.
Supply Voltage Range	2.5 to 16 VDC nominal, up to 50mV p-p ripple
Supply Current	17 mA typ.
ESD Circuit Protection	15 kV air discharge
P 1dB Output	11 dBm typ.
Group Delay	20 ns @ L1, 14 ns @ L2, 20 ns @ L5

Mechanical Diagram - Units in 'mm' or 'inches' where specified

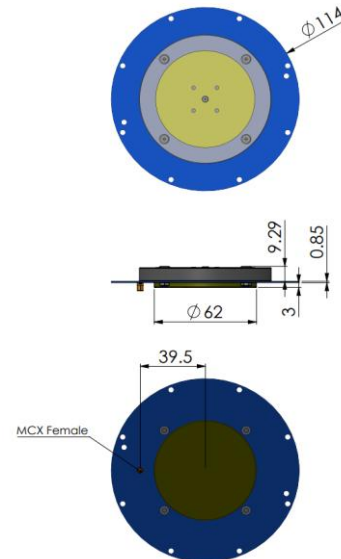

Ordering Information

Part Number **33-AC4990EXF-114**

Please refer to our **Ordering Guide** to review available radomes and connectors at: <https://at.callian.com/gnss/information-support/part-number-ordering-guide/>