

NO	DESCRIPTION	MATERIAL	Q'TY	FINISH	REMARK
1	SHELL	BRASS	1	NICKEL	B-SMA0043-N
2	GASKET	SI RUBBER	1	RUBBER	RU-0008
3	WASHER	BRASS	1	NICKEL	W-0012
4	INSULATION	TEFLON	1	TEFLON	I-0115T
5	BODY	BRASS	1	NICKEL	B-SMA1036-N
6	PIN	BRASS	1	GOLD	P-SMA0717-G
7	RING	BRASS	1	NICKEL	R-0010-N

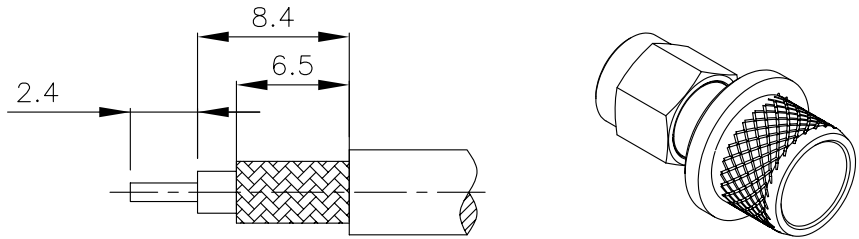

D

D

C

C

B

B

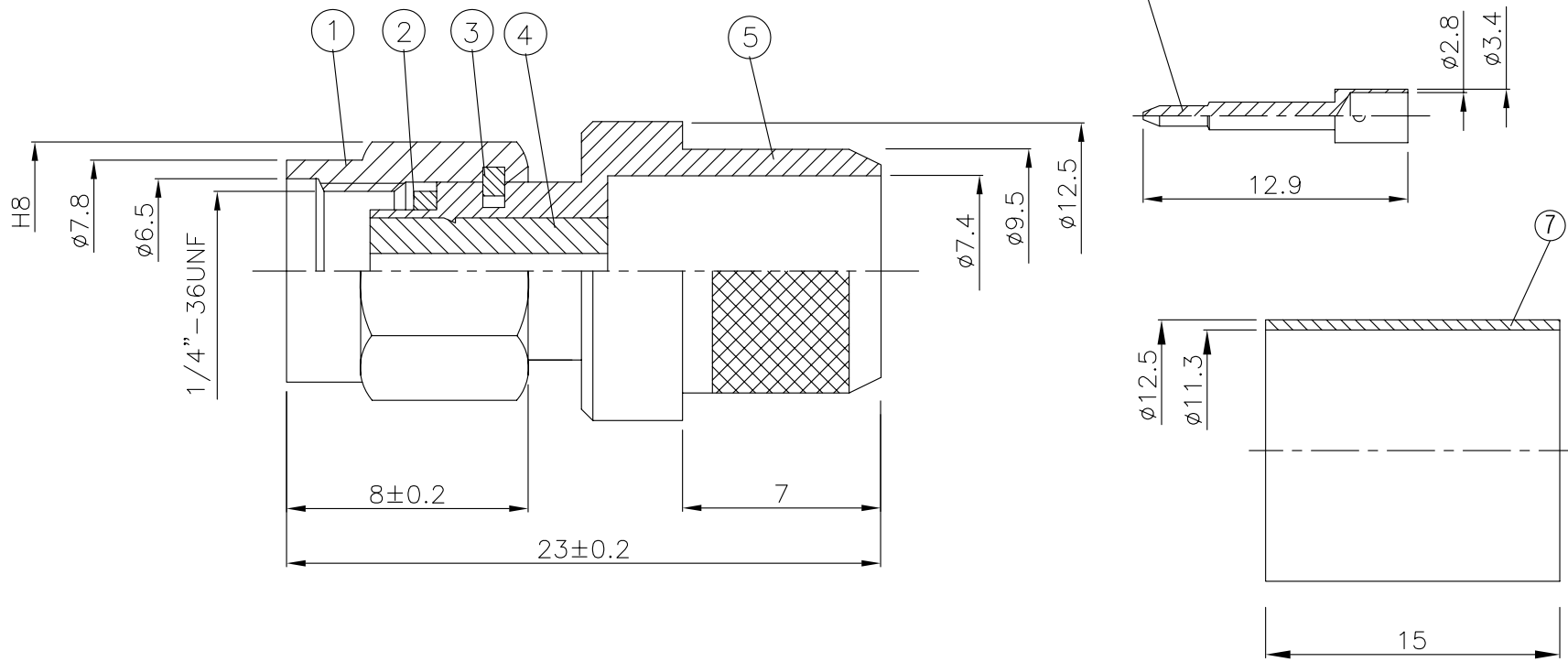

A

A

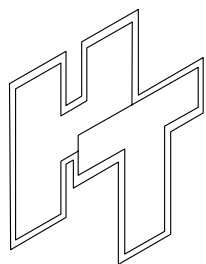

HUS-TSAN GROUP CO., LTD
P.O. BOX 40-76.TAINAN TAIWAN,R.O.C.
TITLE SMA MALE CRIMP FOR LMR-400
PART NO. SMA-03S-TGN
DRAWING NO. SMA-03S-TGN

DRAWN MARY
CHECKED 蘇志欣
Q.A. 蘇姿潔
APPROVAL 徐燦霖
REVISION

DATE 96.06.21
DATE
DATE
DATE

DIMENSIONS ARE IN MILLIMETERS
UNLESS OTHERWISE SPECIFIED TOLERANCES
0.5-5=±0.2 120-315=±1
5-30=±0.4 315-1000=±1.6
30-120=±0.6 1000-2000=±2.4
SCALE 4:1 SIZE A

REVISION

DESCRIPTION	ENGINEER

4

3

2

1