

NO	DESCRIPTION	MATERIAL	Q'TY	FINISH	REMARK
1	BODY	BRASS	1	NICKEL	B-FME0006F-N
2	PIN	BRASS	1	GOLD	P-FME0006F-G
3	INSULATION	DELRIN	1	DELRIN	I-0091D
4	RING	BRASS	1	NICKEL	R-0007-N

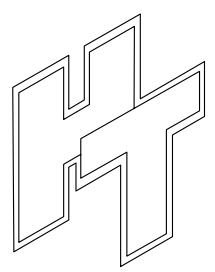
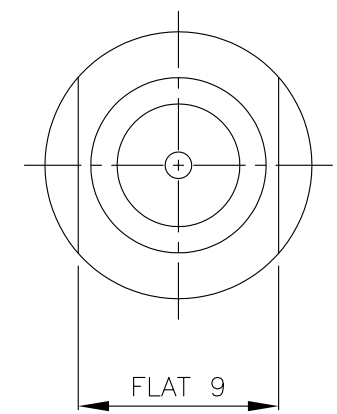
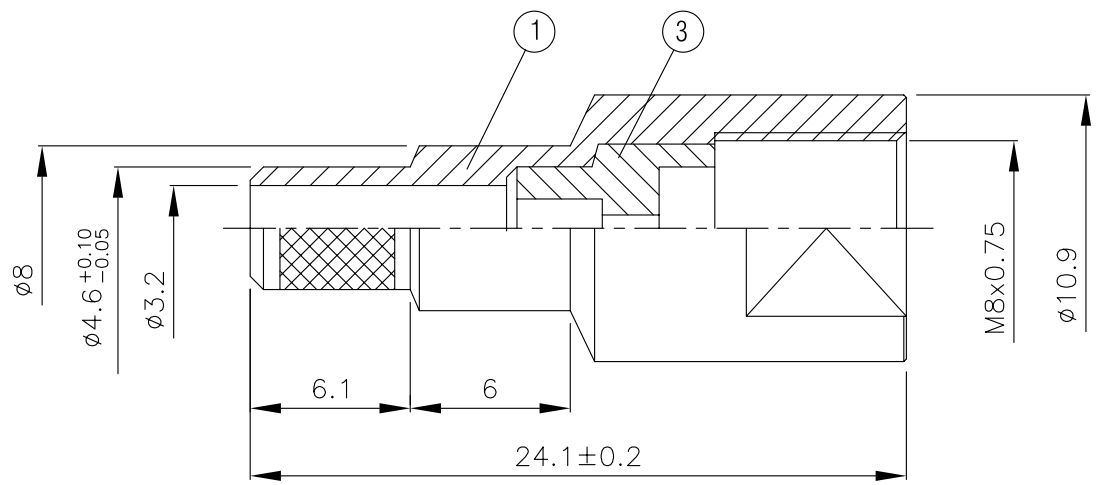
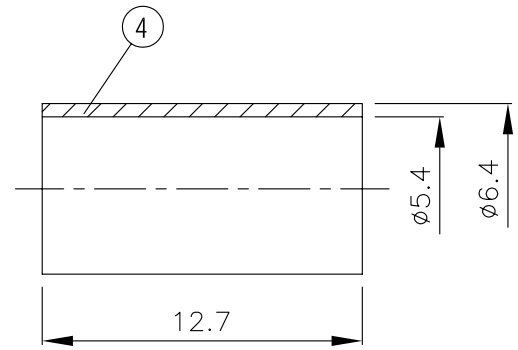
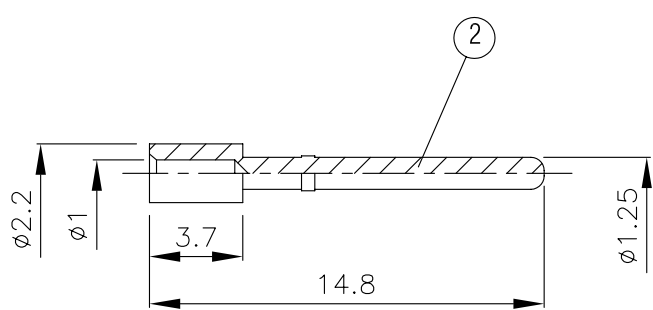
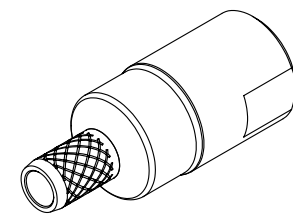

HUS-TSAN GROUP CO., LTD.
P.O.BOX 40-76.TAINAN.TAIWAN,R.O.C.
TITLE FME MALE CRIMP FOR RG58U
PART NO. FME-04F-TGN
DRAWING NO. FME 04F TGN

DRAWN MARY DATE 96.07.07
CHECKED 蘇志欣 DATE
Q.A. 蘇姿潔 DATE
APPROVAL 徐燦霖 DATE
REVISION DATE

DIMENSIONS ARE IN MILLIMETERS
UNLESS OTHERWISE SPECIFIED TOLERANCE
0.5-5=±0.2 120-315=±1
5-30= ±0.4 315-1000=±1.6
30-120±0.6 1000-2000=±2.4
SCALE 4:1 SIZE A

REVISION	
DESCRIPTION	ENGINEER