

NO	DESCRIPTION	MATERIAL	Q'TY	FINISH	REMARK
1	NUT	BRASS	1	NICKEL	N-0068-N
2	BODY 1	BRASS	1	NICKEL	B-N1293-N
3	WASHER 1	BRASS	1	NICKEL	W-0087-N
4	RUBBER	SI RUBBER	1	RUBBER	RU-0053
5	WASHER 2	BRASS	1	NICKEL	W-0086-N
6	INSULATION	TEFLON	1	TEFLON	I-0296T
7	PIN	BRASS	1	GOLD	P-N0157-G
8	WASHER 3	BRASS	1	NICKEL	W-0014-N
9	BODY 2	BRASS	1	RUBBER	B-N0033-N
10	RUBBER	SI RUBBER	1	RUBBER	RU-0007
11	BODY 3	BRASS	1	NICKEL	B-N0032-N

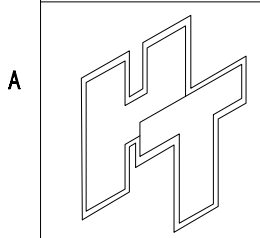
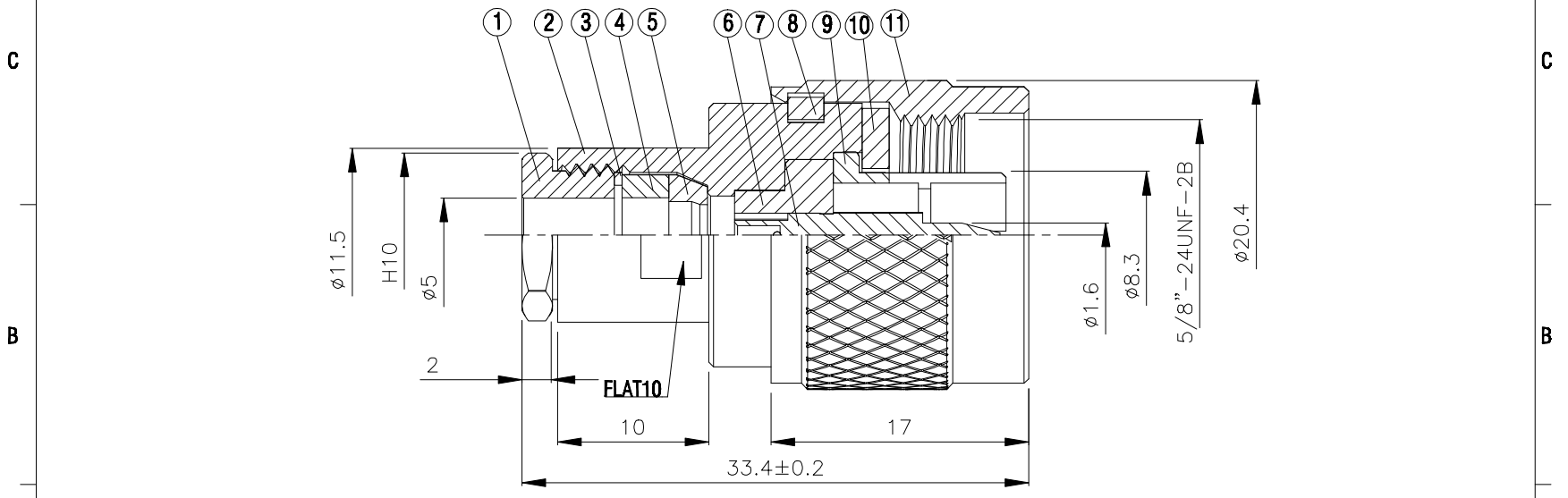
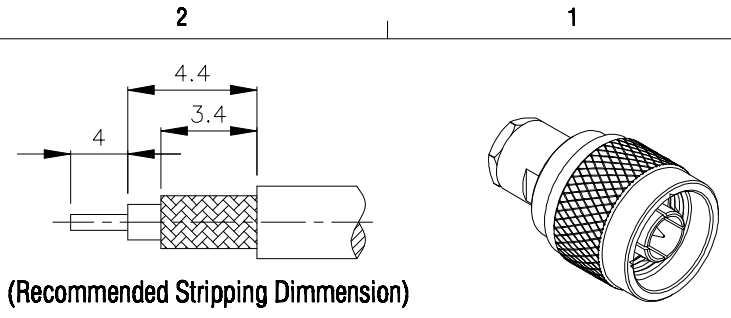

**HUS-TSAN GROUP CO., LTD.**  
P.O. BOX 40-76. TAINAN. TAIWAN. R.O.C.  
**TITLE N MALE CLAMP FOR RG-58/U**  
**PART NO. N-01F-TGN-1**  
**DRAWING NO. N 01F TGN-1**

**DRAWN MARY** **DATE 97.05.07**  
**CHECKED 蘇志欣** **DATE**  
**Q.A. 蘇姿潔** **DATE**  
**APPROVAL 徐燦霖** **DATE**  
**REVISION** **DATE**

**DIMENSIONS ARE IN MILLIMETERS**  
**UNLESS OTHERWISE SPECIFIED TOLERANCE**  
0.5-5=±0.2    120-315=±1  
5-30=±0.4    315-1000=±1.6  
30-120±0.6    1000-2000=±2.4  
**SCALE 4:1**    **SIZE A**

REVISION	
DESCRIPTION	ENGINEER

4

3

2

1

A

A