

NO	DESCRIPTION	MATERIAL	Q'TY	FINISH	REMARK
1	PIN	BRASS	1	GOLD	P-UHF0117-G
2	INSULATION	DELIN	1	DELIN	I-0024T
3	BODY	BRASS	1	NICKEL	B-UHF1408-N
4	SHELL	BRASS	1	NICKEL	B-UHF1409-N

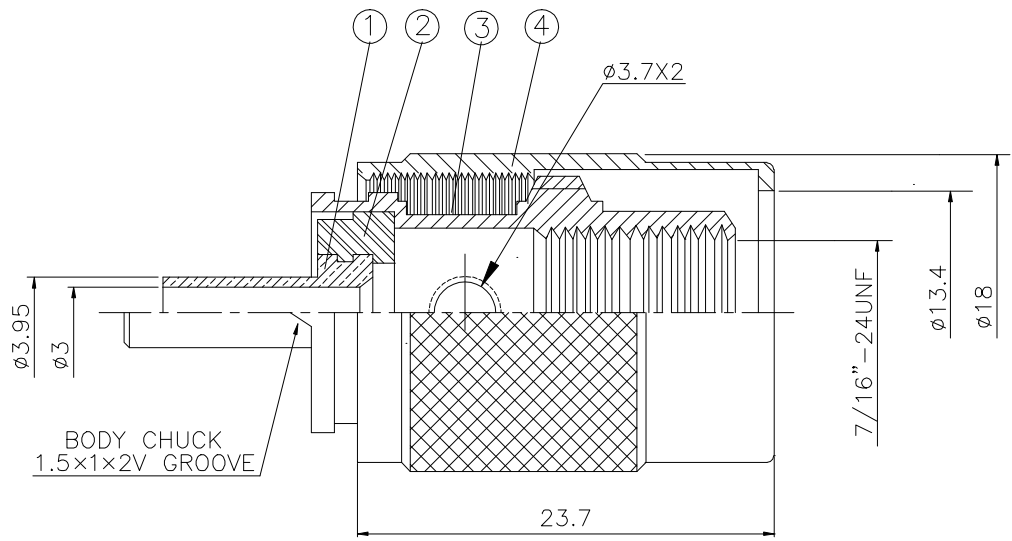
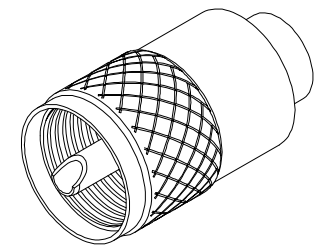

	HUS-TSAN GROUP CO., LTD.		DRAWN	MARY	DATE	98.05.12	DIMENSIONS ARE IN MILLIMETERS		REVISION	
	P.O. BOX 40-76.TAINAN.TAWAN,R.O.C.		CHECKED	蘇志欣	DATE		UNLESS OTHERWISE SPECIFIED TOLERANCE		DESCRIPTION	ENGINEER
	TITLE MALE TWIST ON RG8A/U, 213U		Q.A.	蘇姿潔	DATE		0.5-5=±0.2	120-315=±1		
	PART NO. UHF-07B-TGN-1		APPROVAL	徐燦霖	DATE		5-30=±0.4	315-1000=±1.6		
	DRAWING NO. UHF-07B-TGN-1		REVISION		DATE		30-120=±0.6	1000-2000=±2.4		
				SCALE	4:1	SIZE	A			