

NO	DESCRIPTION	MATERIAL	Q'TY	FINISH	REMARK
1	PIN	BRASS	1	GOLD	P-MCCD0180-G
2	INSULATION	TEFLON	1	TEFLON	I-0141T
3	BODY 1	BE CU	1	GOLD	B-MCCD0300-G
4	BODY 2	BRASS	1	NICKEL	B-MCCD0301-N
5	WASHER	BRASS	1	NICKEL	W-0038-N
6	INSULATION	TEFLON	1	TEFLON	I-0146T
7	RING	BRASS	NICKEL	R-0001-G	

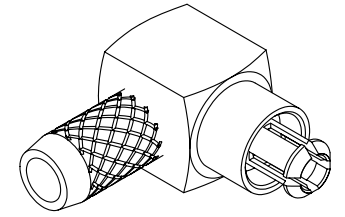

(Recommended Stripping Dimension)

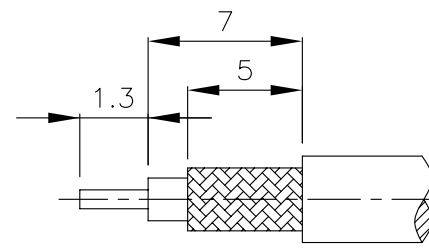
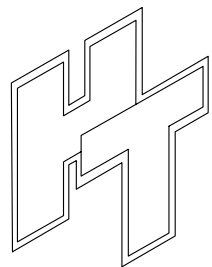
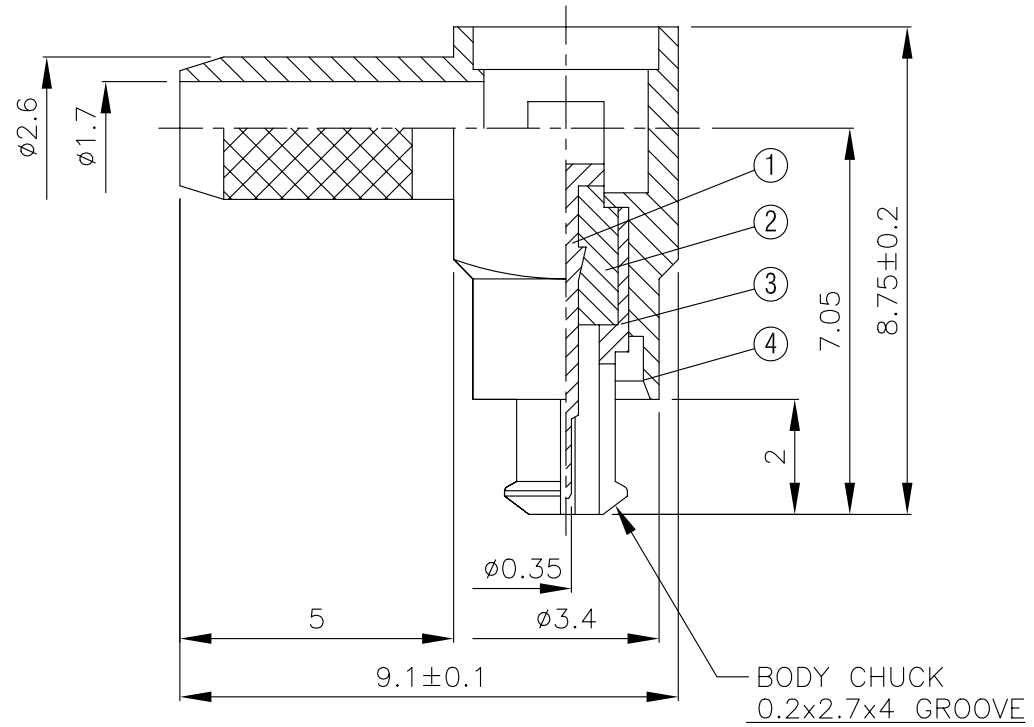
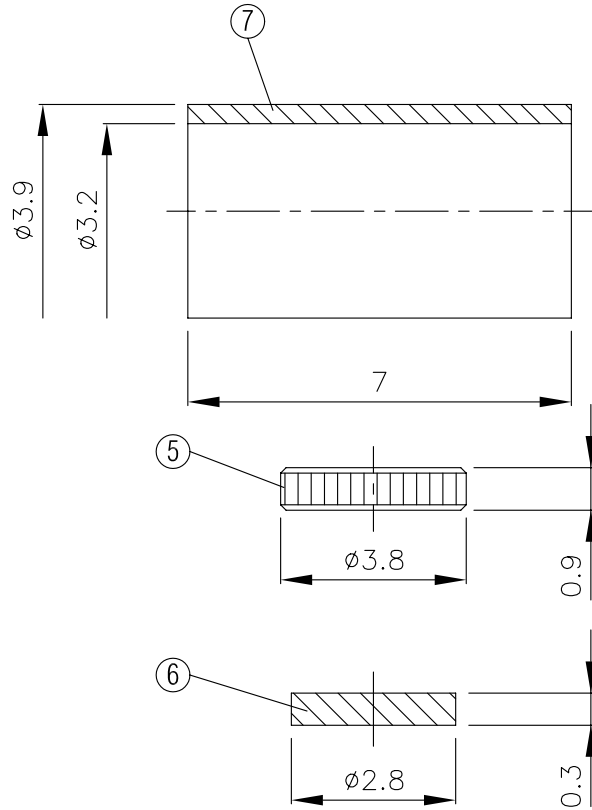

HUS-TSAN GROUP CO., LTD.

P.O. BOX 40-76. TAINAN, TAIWAN, R.O.C.

TITLE MC-CARD MALE ANGLE CRIMP FOR RG 316U, 174U

PART NO. MCCD-03LV1-TGN

DRAWING NO. MCCD 03LV1 TGN

DRAWN	MARY	DATE	96.04.16
CHECKED	黃巧君	DATE	
Q.A.	蘇姿潔	DATE	
APPROVAL	徐燦霖	DATE	
REVISION		DATE	

DIMENSIONS ARE IN MILLIMETERS

UNLESS OTHERWISE SPECIFIED TOLERANCE

0.5-5=±0.2	120-315=±1
5-30=±0.4	315-1000=±1.6
30-120±0.6	1000-2000=±2.4

SCALE 4:1 SIZE A

REVISION

DESCRIPTION ENGINEER