

NO	DESCRIPTION	MATERIAL	Q'TY	FINISH	REMARK
1	BODY 1	BRASS	1	NICKEL	B-N0047-N
2	INSULATION	TEFLON	1	TEFLON	I-0064T
3	BODY 2	BRASS	1	NICKEL	B-N0033-N
4	WASHER	PH.BRONZE	1	NICKEL	W-0014
5	GASKET	SI RUBBER	1	RUBBER	RU-0007
6	BODY 2	BRASS	1	NICKEL	B-N0032-N
7	RING	BRASS	1	NICKEL	R-0010-N
8	PIN	BRASS	1	GOLD	P-N0158-G

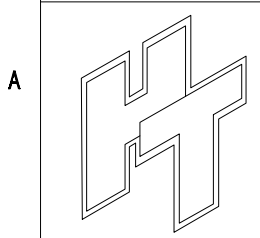
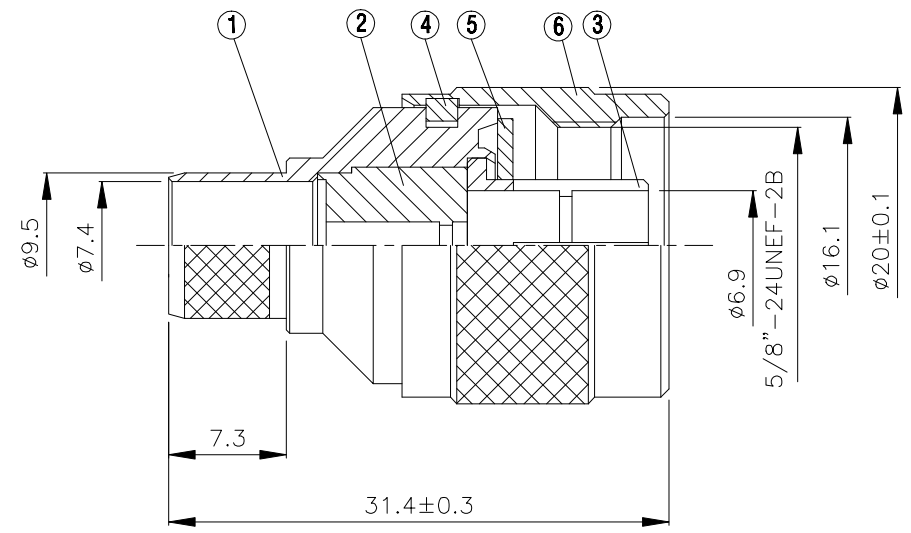
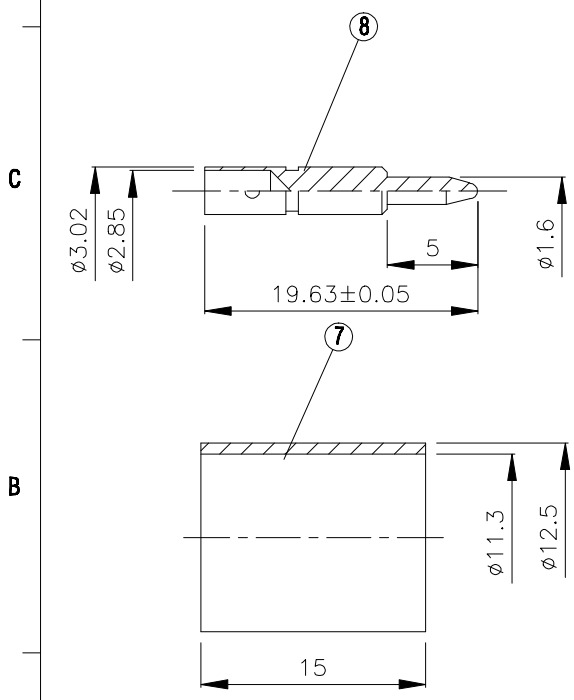
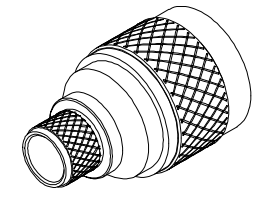
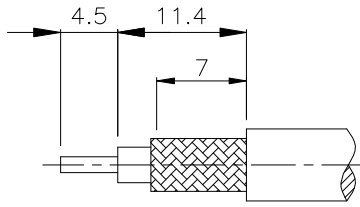

HUS-TSAN GROUP CO., LTD.
P.O. BOX 40-76. TAINAN. TAIWAN, R.O.C.
TITLE N MALE CRIMP FOR LMR-400
PART NO. N-03S-TGN
DRAWING NO. N 03S TGN

DRAWN MARY **DATE 96.06.18**
CHECKED 蘇志欣 **DATE**
Q.A. 蘇姿潔 **DATE**
APPROVAL 徐燦霖 **DATE**
REVISION **DATE**

DIMENSIONS ARE IN MILLIMETERS
UNLESS OTHERWISE SPECIFIED TOLERANCE
0.5-5 = ±0.2 120-315 = ±1
5-30 = ±0.4 315-1000 = ±1.6
30-120 = ±0.6 1000-2000 = ±2.4
SCALE 4:1 **SIZE A**

REVISION
DESCRIPTION **ENGINEER**

4

3

2

1

A

A