

NO	DESCRIPTION	MATERIAL	Q'TY	FINISH	REMARK
1	BODY 1	BRASS	1	NICKEL	B-N0497-N
2	PIN	BRASS	1	GOLD	P-N0342-G
3	INSULATION	TEFLON	1	TEFLON	I-0247T
4	WASHER	PH.BRONZE	1	NICKEL	W-0014
5	GASKET	SI RUBBER	1	RUBBER	RU-0007
6	BODY 2	BRASS	1	NICKEL	B-N0032-N
7	BODY 3	BRASS	1	NICKEL	B-N0033-N
8	BODY 4	BRASS	1	NICKEL	B-N0498-N
9	WASHER	BRASS	1	NICKEL	W-0033-N
10	RING	BRASS	1	NICKEL	R-0007-N

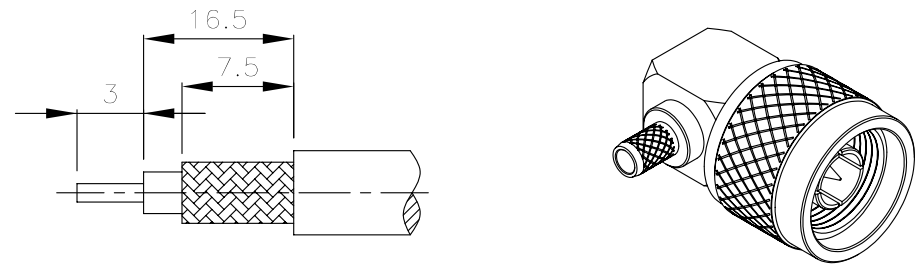

D

D

C

C

B

B

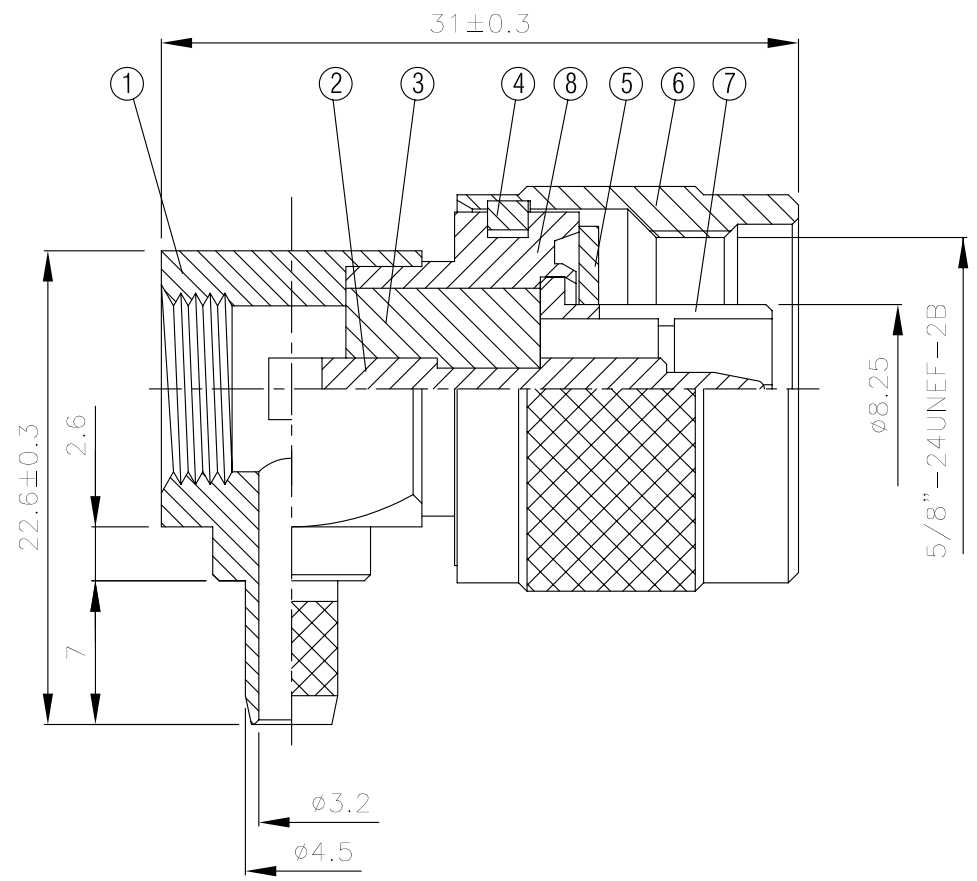
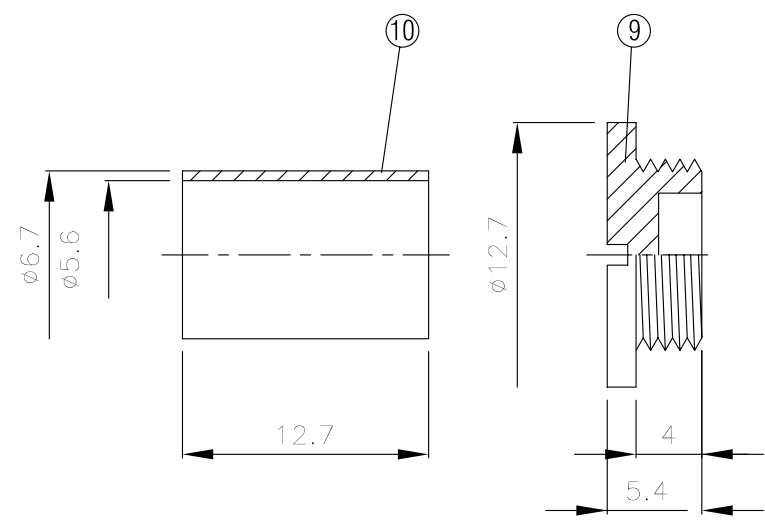

A

A

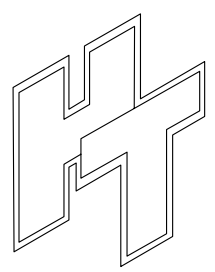

HUS-TSAN GROUP CO., LTD.
P.O.BOX 40-76.TAINAN.TAIWAN,R.O.C.
TITLE N ANGLE MALE CRIMP FOR RG 58/U
PART NO. N-35F-TGN
DRAWING NO. N 35F TGN

DRAWN	MARY	DATE	97.02.20
CHECKED	黃巧君	DATE	
Q.A.	蘇姿潔	DATE	
APPROVAL	徐燦霖	DATE	
REVISION		DATE	

DIMENSIONS ARE IN MILLIMETERS			
UNLESS OTHERWISE SPECIFIED TOLERANCE			
0.5-5=±0.2	120-315=±1		
5-30=±0.4	315-1000=±1.6		
30-120=±0.6	1000-2000=±2.4		
SCALE	4:1	SIZE	A

REVISION	
DESCRIPTION	ENGINEER

4

3

2

1