

| NO | DESCRIPTION | MATERIAL | Q'TY | FINISH | REMARK |
|----|-------------|-----------|------|--------|-------------|
| 1 | BODY 1 | BRASS | 1 | NICKEL | B-TNC0083-N |
| 2 | RUBBER | SI RUBBER | 1 | RUBBER | RU-0010 |
| 3 | WASHER 1 | BRASS | 1 | NICKEL | W-0026-N |
| 4 | WASHER 2 | BRASS | 1 | NICKEL | W-0024-N |
| 5 | WASHER 3 | BRASS | 1 | NICKEL | W-0025-N |
| 6 | INSULATION | TEFLON | 1 | TEFLON | I-0130T |
| 7 | BODY 2 | BRASS | 1 | NICKEL | B-TNC0085-N |
| 8 | PIN | BRASS | 1 | GOLD | P-TNC0054-N |
| 9 | RING | BRASS | 1 | NICKEL | R-0007-N |

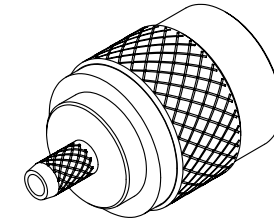

(Recommended Stripping Dimension)

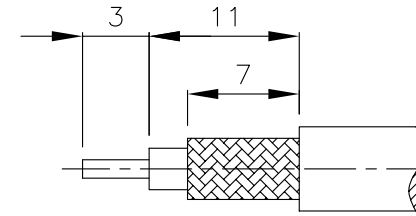
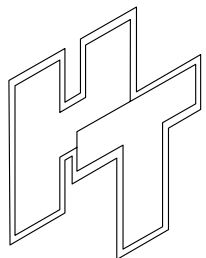
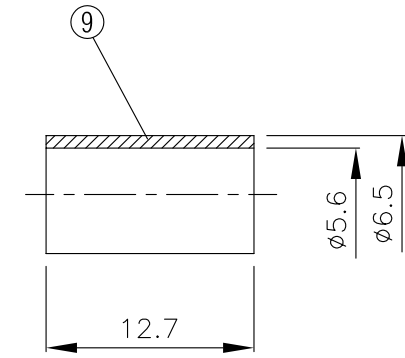
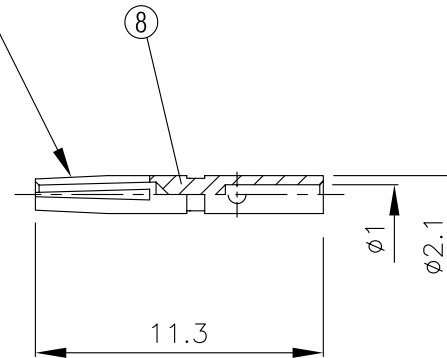
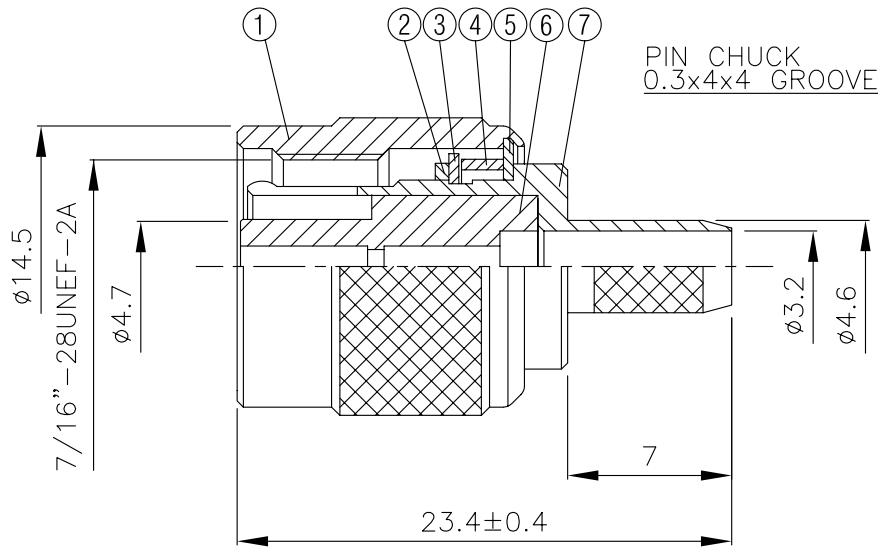

HUS-TSAN GROUP CO., LTD.

P.O.BOX 40-76.TAINAN.TAIWAN,R.O.C.

TITLE TNC MALE CRIMP FOR REVERSE POLARITY (RG 58U, RG141A/U)

PART NO. TNC-05F-TGN-RP

DRAWING NO. TNC 05F TGN RP

DRAWN MARY DATE 95.12.06

CHECKED 黃巧君 DATE

Q.A. 蘇姿潔 DATE

APPROVAL 徐燦霖 DATE

REVISION DATE

DIMENSIONS ARE IN MILLIMETERS

UNLESS OTHERWISE SPECIFIED TOLERANCE
 0.5-5=±0.2 120-315=±1
 5-30=±0.4 315-1000=±1.6
 30-120±0.6 1000-2000=±2.4

SCALE 4:1 SIZE A

REVISION

DESCRIPTION ENGINEER

D

C

B

A

D

C

B

A